

# LINEAR POSITION TRANSDUCERS

## "0-10 VDC Analog Measuring"

# LTM-V



- Stroke up to 1000 mm
- Absolute measurement of displacement
- 0-10 VDC Analog output and other models
- Resolution 0,01 mm
- Very long life up to 100 million movements
- Protection Class IP64
- High independent linearity 0,05 %
- The grooves provide an excellent alternative to the usual system of fastening with brackets
- CE Declaration confirmity

LTM-V is a high precision 0-10VDC analog output industrial linear motion transducer with a long lasting conductive track suitable for absolute position measuring in control and measurement applications. Designed for the direct, absolute measurement of displacement or length in control regulation and measuring applications. High resolution (0.01 mm) combined with a stroke length of up to 1000 mm permits the accurate measurement of linear displacement. Rack and pinions or similar devices are not required because the design of the transducers is such that they may be built directly into the mechanical system.

**Applications:** LTM-V Series can be used in a wide range of applications in mechanical and vehicle engineering industries as well as in automation and robotics technologies, combining remarkable robustness with high accuracy.

LTM-V Series 0-10 VDC Analog Output Linear Transducers are mainly used in :

- Press Brake Machines
- Horizontal Band Saw Machines
- Transfer Machines
- Hydraulic Machines
- Sheet metal working machines
- Bending presses
- Plastic & Metal Injection Machines
- Textile Machines
- Robotics/materials handling
- Profile Cutting Machines
- CNC Pipe Twisting Machines
- Plastic Extrusion Machines

### Technical Specifications

Defined Electrical Ranges	50 - 75 - 100 - 125 - 150 - 175 - 200 - 225 - 250 - 275 - 300 - 325 - 350 - 360 - 375 - 400 - 450 - 500 - 550 - 600 - 650 - 700 - 750 - 800 - 900 - 1000
Output Signals	0-10 VDC Analog Output ( other models optional )
Independent Linearity	± %0,05
Electrical Connection	4 pin female DIN43650
Power Supply	24 VDC
Protection Class	IP64
Temperature Range	-30°C +100°C
Life	100 million movements
Mechanical Fixing	Adjustable distance clamps
Rod Material	Stainless steel
Housing Material	Anodized aluminium

### Order Code

Model No

Defined Stroke Range

Several standard lengths from 50 mm to 1000 mm

L T M - 3 0 0 - V

Output

V : 0-10 VDC Analog Voltage Output

\*\*Optional 0-5 VDC Voltage Output

### Included in Delivery

- 1 Connector / 4 pin female socket ( DIN43650 )
- 2 Quantity Fixing Clamps
- 4 Quantity Screw

### Recommended Accessories

- Pivot head
- Process-controlled indicators "ALP Series"



## Dimension

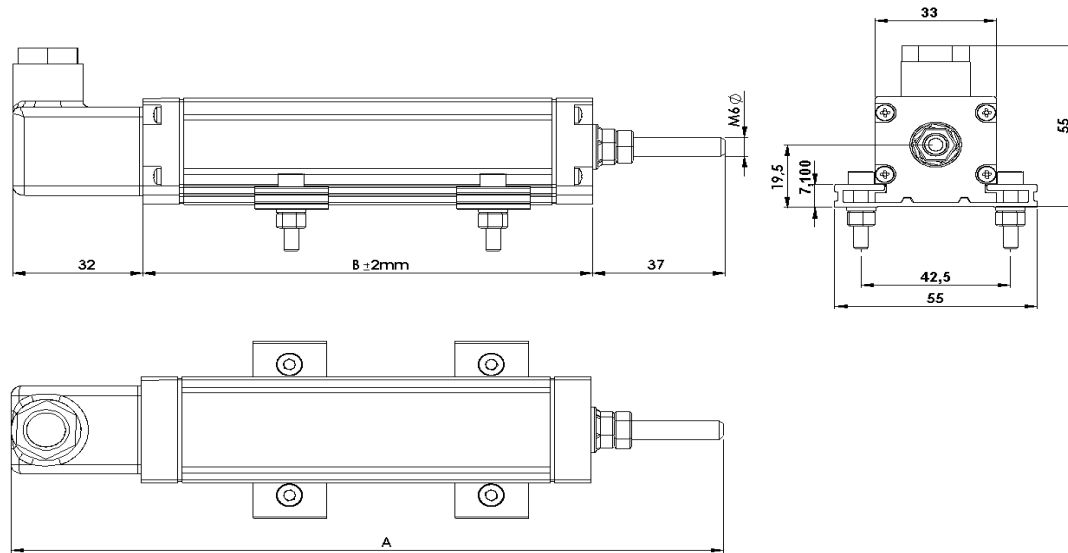

## Connections

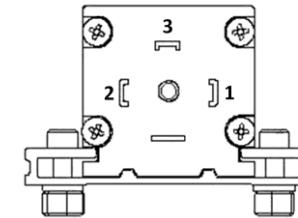

### 0-10 VDC ANALOG OUTPUT

1. +24 VDC Supply
  2. Analog Output
- 0-10 VDC Voltage Output
3. GROUND
  4. SHIELD

TYPE	LTM 50	LTM 75	LTM 100	LTM 125	LTM 150	LTM 175	LTM 200	LTM 225	LTM 250	LTM 275	LTM 300	LTM 325	LTM 350	LTM 360	LTM 375	LTM 400	LTM 450	LTM 500	LTM 550	LTM 600	LTM 650	LTM 700	LTM 750	LTM 800	LTM 900	LTM 1000	
STROKE	50	75	100	125	150	175	200	225	250	275	300	325	350	360	375	400	450	500	550	600	650	700	750	800	900	1000	
MECHANICAL STROKE (mm)	54	79	104	129	154	179	204	229	254	279	304	329	354	364	379	404	454	504	554	604	654	704	754	804	904	1004	
ELECTRICAL STROKE (mm)	50	75	100	125	150	175	200	225	250	275	300	325	350	360	375	400	450	500	550	600	650	700	750	800	900	1000	
<b>MECHANICAL DIMENSIONS</b>																											
TOTAL LENGTH (A) (mm) ±2 mm	195	220	245	270	295	320	345	370	395	420	445	470	495	505	520	545	595	645	695	745	795	845	895	945	1045	1145	
BODY LENGTH (B) (mm) ±2 mm	126	151	176	201	226	251	276	301	326	351	376	401	426	436	451	476	526	576	626	676	726	776	826	876	976	1076	