

- Optical Measuring
- Glass Scale
- Scanning Unit Guided on Scale 5 Via Ball Bearings
- Single Gasket Protection
- High Resolution Up to 1 μm
- 5 VDC TTL Quadrature or 1 Vpp Sinusoidal
- Easy Mounting
- Measuring Lengths 50 mm – 1000 mm
- 60 m/min Travel Velocity

ALS series Optic Linear Encoder Systems are protected from dust, chips and splash fluids and are ideal for operation on machine tools.

Sealed linear encoders are available with full-size scale housings for high resistance to vibration up to 1000 mm measuring length.

### Technical Specifications

Resolution	1μm, 5μm or 1Vpp Sinusoidal
Output	5VDC TTL Quadrature or 1Vpp Sinusoidal
Output Signals	TTL: A, /A, B, /B, Z, /Z
Grating pitch / Signal Period	20 μm
Power Supply	5 VDC
Accuracy	± 10 μm
Travel Velocity	60 m/min
Repeatability	± 1 Pulse
Housing Material	Aluminum
Reference Mark	1 Reference Mark, Every 50 mm
Storage Temperature	-40 to +55°C
Operating Temperature	0 to +50°C
Protection Class	IP54
Cable Length	50 – 500 mm scale (3 meters armored cable ) 600 – 2000 mm scale (5 meters armored cable)

### Connection

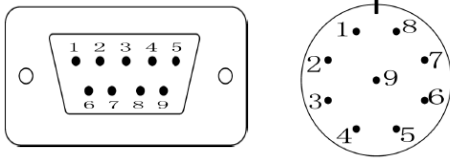

PIN NR	CABLE COLOUR	TTL SIGNAL	SINUS SIGNAL
1	GREY	A	0°
2	BROWN	/B	180°
3	RED	+5VDC	+5VDC
4	BLACK	0V – GND	0V – GND
5	BLUE	/A	90°
6	GREEN	B	270°
7	YELLOW	/Z	Z
8	WHITE	Z	VACANT
9	-	SHIELD	SHIELD

### Mechanical Dimensions

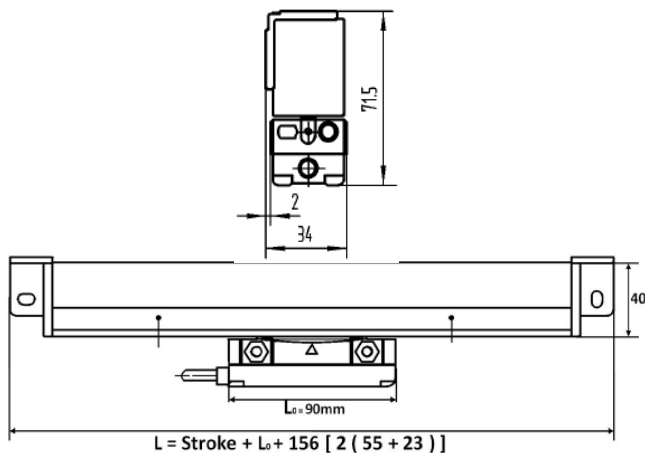

### Order Code

#### Model

#### Measuring Stroke

- 50 : 50 mm
- 200 : 200 mm
- 500 : 500 mm
- 1000 : 1000 mm

ALS 5 - X - X X X

#### Resolution

- 01 : 1μm
- 05 : 5μm
- S : Sinusoidal

#### Signal Output Type

6 : A, /A, B, /B, Z, /Z

Standard, 1 Z signal per 50 mm  
Optional one Z reference signal

### Atek Sensor Technology A.S.